

## Technical data:

working width	1'200 – 2'400 mm
operating speed	up to 80 m/min
coating methods	rotogravure and multi-roll
coating weights	3 – 80 gsm (full surface or dot coating)
adhesives	thermoplastic hotmelt reactive PU hotmelt

## Description:

CAVI-2-COAT is a multifunctional machine for coating and laminating. The coating modus can be changed between rotogravure modus and a variety of full-surface coating by just press a button. For specific coatings it's necessary to change the engraved roll with a smooth roll. This machine includes innovative technologies for highest coating precision with enormous flexibility and short downtime.

Reliability and reproducibility is a matter of course.

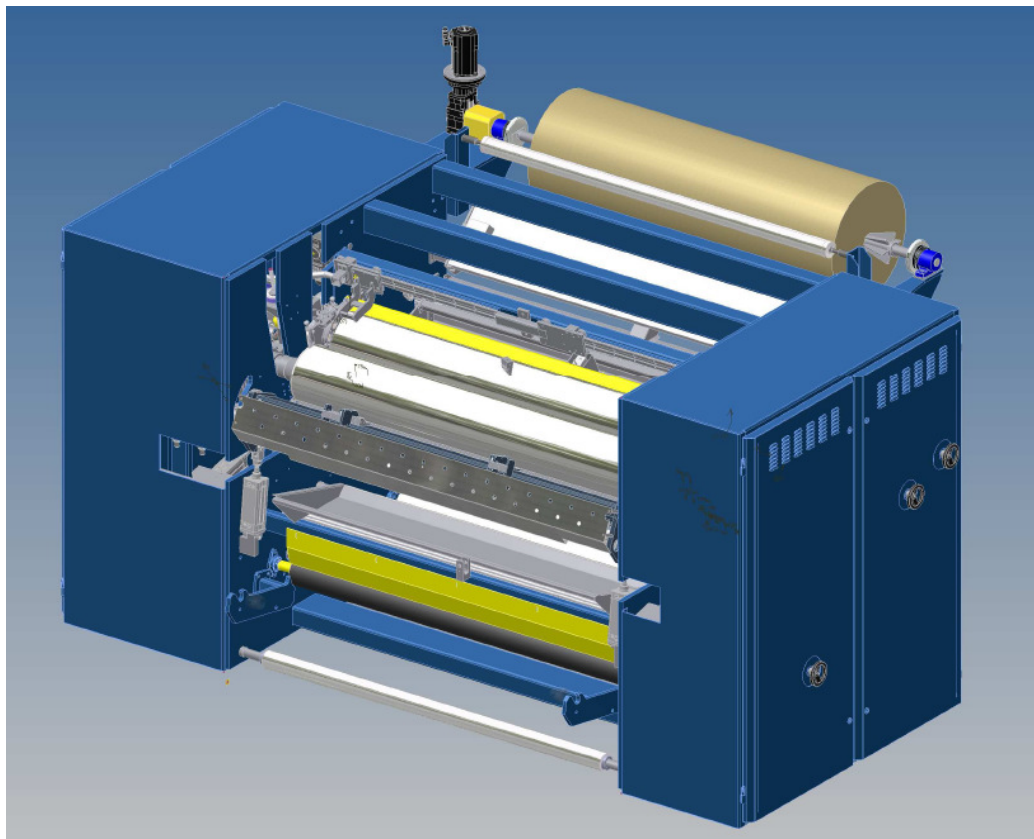

## Santex AG

CAVITEC  
Fliegeneggstrasse 9  
CH-9555 Tobel  
Switzerland

Phone +41 71 918 66 66  
Telefax +41 71 918 66 80  
Email: [cavitec@cavitec.ch](mailto:cavitec@cavitec.ch)  
Internet [www.santex-group.com](http://www.santex-group.com)

# CAVI-2-COAT

**Coating and Laminating  
for multiple purpose**

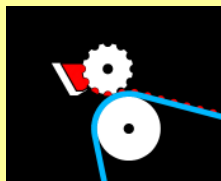

**Rotogravure**

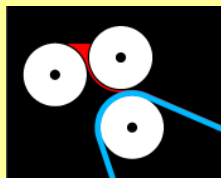

**Multi Roll  
Direct Coating**

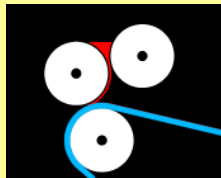

**Multi Roll  
Reverse Coating**

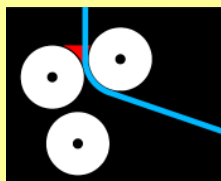

**Multi Roll  
Both side Coating**

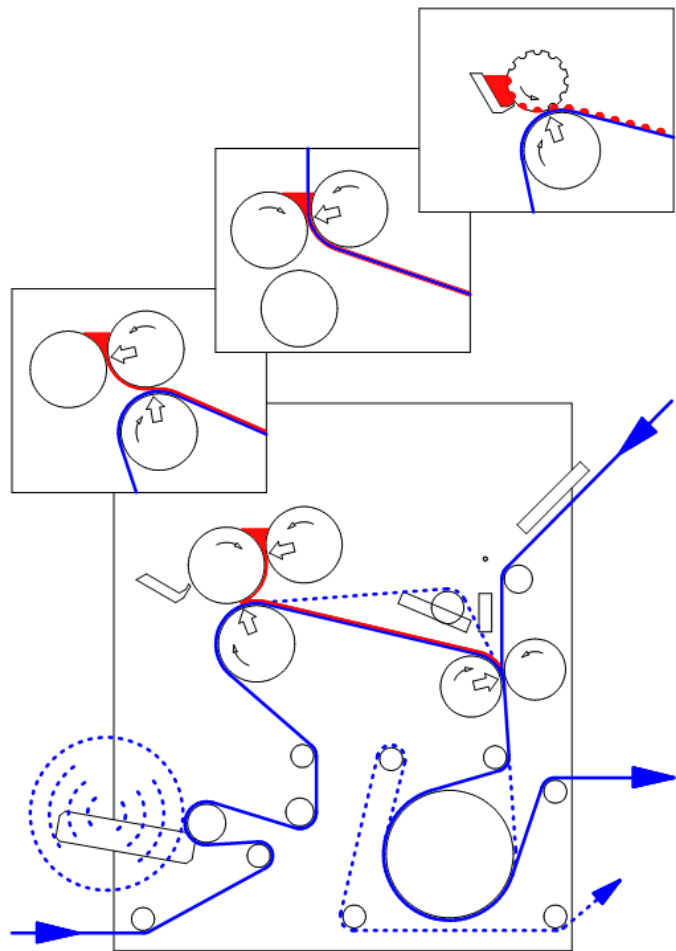

**Our world has changed . . . . .  
Success depends on flexibility!**

***New at  
ITMA 2011***